



Extraction & Lance Reset Tools

CAT-RE-169-01

CAT-EX-169-01

INSTRUCTION SHEET

POWER CONNECTOR
IPBD SERIES (CC69-X)

Rev. Date: 7/7/2005

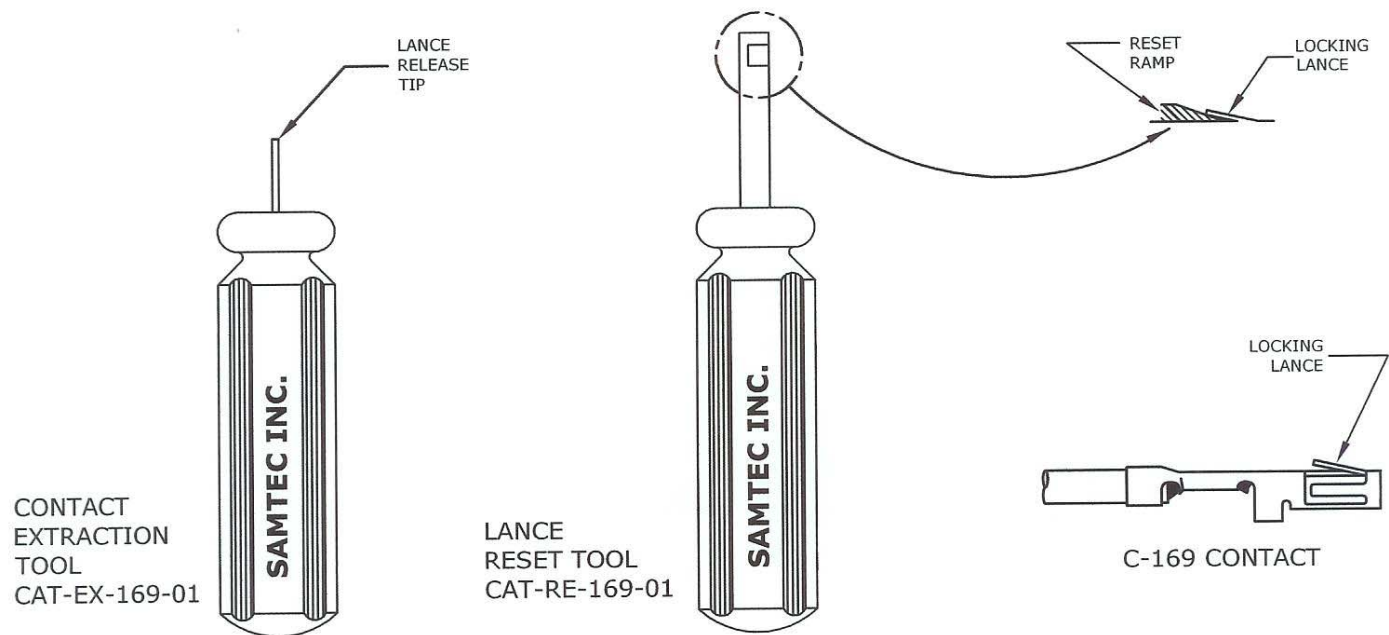

FIGURE 1

1. INTRODUCTION

Contacts can be safely removed from a housing cavity and reinserted into a new position by using the extraction tooling shown in Figure 1. This instruction sheet covers the use of the SAMTEC Extraction Tool CAT-EX-169-01 and Lance Reset Tool CAT-RE-169-01. These tools are intended to aid in the removal of the C-169, Power Mate contacts from housings and reset the lance position of the removed contact.

2. CUSTOMER SERVICE

Farther tooling and product application assistance is available by contacting the **Samtec Application Service Line-(1-800-SAMTEC9)** 8:00 AM to 5:00 eastern time. To expedite your inquiry, have the pertinent part numbers for the product and tooling.

3. DESCRIPTION

Each tool handle is marked with the contact number for which it was designed. Make sure it matches the product numbers you are working with.

The Power Mate contact has a retaining lance that can be released through an access cavity located in the front of the housing as shown in Figure 2. The Extraction Tool is inserted into the cavity to depress the lance the correct amount for contact removal.

CAUTION- Do not use an unintended tools to release the lance. This can cause damage to the lance and weaken its ability retain the reinserted contact in the housing.

The lance reset tool is used to adjust the height of the contact lance height, if necessary, after extraction. This assures that the lead retention force will be correct after re-insertion.

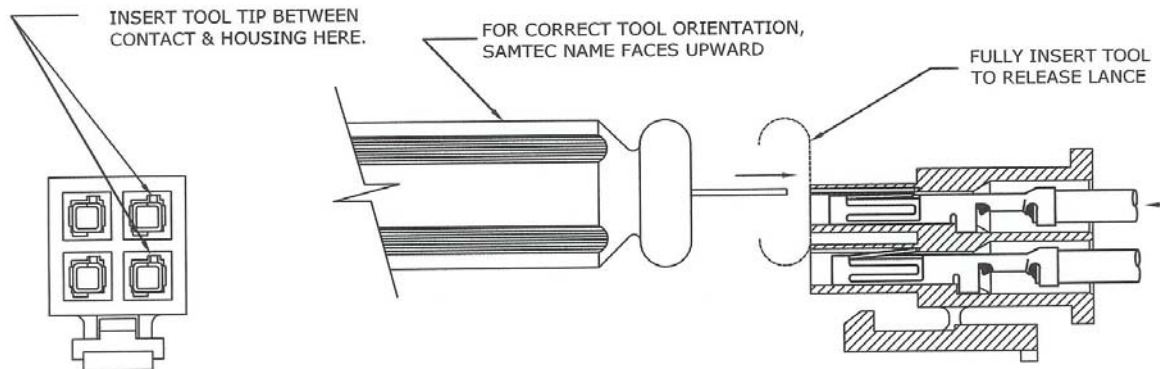
**FIGURE 2****4. EXTRACTION PROCEDURE**

The following steps are recommended:

1. Push the desired lead forward to the bottom of its cavity. This will provide clearance for the lance to be depressed.
2. From the mating side of the housing, fully insert the Extraction Tool into the lance cavity with the Samtec name facing upward as shown in Figure 2. The lance cavity is located in the upper right corner of the contact cavity with the housing latch facing down. This is typical for all rows of contacts.
3. Maintain forward pressure on the tool then grip the lead and pull the contact from it's cavity.

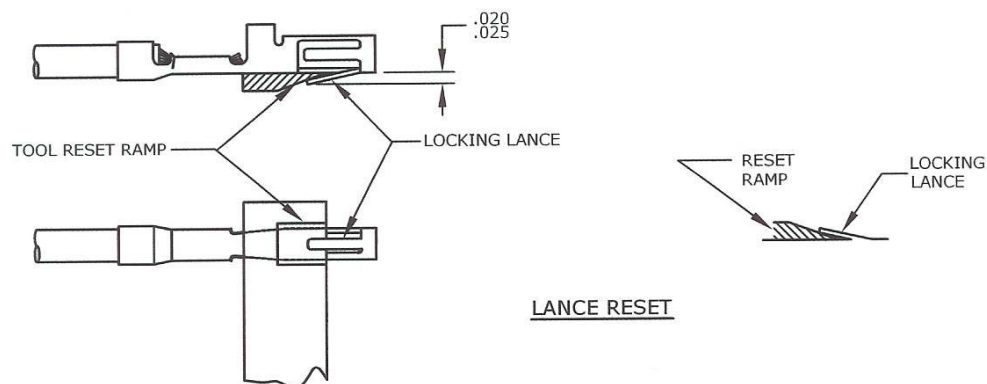
**FIGURE 3****5. LOCKING LANCE RESET PROCEDURE**

Before reinserting an extracted contact, it is necessary to check the lance height to assure the proper retention in the housing as shown if Figure 3. The lance height should be .020 to .025 high. If adjustment is necessary, proceed as follows:

1. Align the reset tool so that the ramp is facing the open portion of the locking lance.



**POWER CONNECTOR
IPBD SERIES (CC69-X)**

Rev. Date: 7/7/2005

2. Slide the locking lance under the locking lance until the height appears to be correct.

3. Recheck the lance height. Repeat setting procedure if necessary.

6. CONTACT RE-INSERTION

In all rows, the locking lance must be **facing away from the housing latch** to correctly engage the contact in the cavity. Push the contact straight into the cavity until an audible **click** is heard. Give the lead a light tug to confirm that the contact is locked in place.